

PRODUCT NUMBER

XXXXX-YYY HTLF

- LEAD FREE OPTION  
SEE NOTE 1,8
- TUBE PACKAGING OPTION  
SEE NOTE 1
- HIGH TEMPERATURE PLASTIC  
SEE NOTE 1
- NO OF  
POSITIONS  
SEE NOTE 1
- PIN PLATING  
SEE SHEET 2
- BASE PART NO.

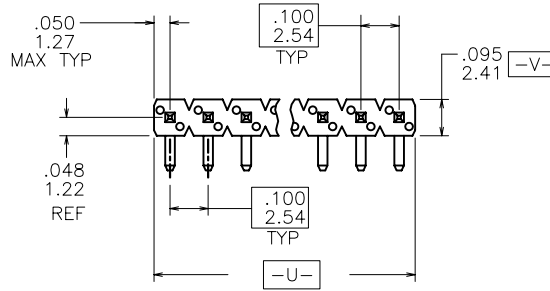

TOP VIEW

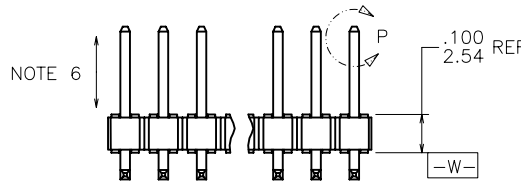

SIDE VIEW

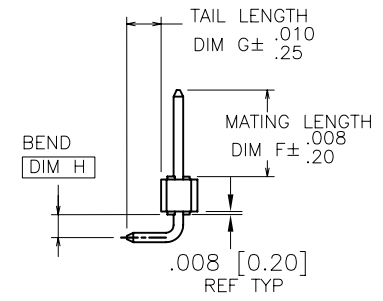

END VIEW

$\phi$	$\phi.020/0.51$	M	U	M	V	S	W
--------	-----------------	---	---	---	---	---	---

NOTE 4

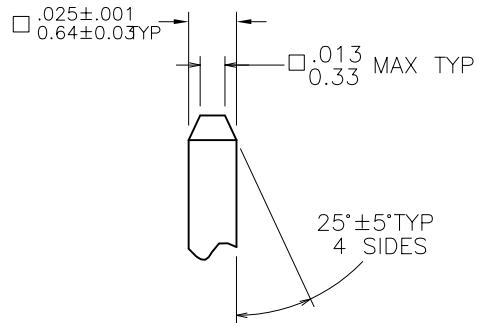

DETAIL P  
TYP BOTH ENDS

mat'l. code SEE NOTES 2 & 3		surface ISO 1302		tolerance ISO 406 ISO 1101		projection INCH/MM		product family BERGSTIK	
ltr	ec'n no	dr	date	tolerances unless otherwise specified		INCH/MM		title BERGSTIK® II HEADER .100/2.54cc SR R/A	
AM	V20790	GIP	04/23/02	angles	linear	scale 2:1		dwg no 68015	
AN	V21800	TAB	12/17/02					sheet 1 of 4 size A3	
AP	M04-0234	MHT	12/29/04	0°±2'				type Product Customer Drawing	
AR	M05-0072	MHT	5/03/05	dr	T.BREWBAKER	01/31/95			
AS	M06-0268	MHT	7/17/06	engr	T.HANNA	01/31/95			
AT	M06-0346	MHT	9/04/06	chr	T.HANNA	01/31/95			
AU	M08-0154	MHT	5/27/08	appd	T.HANNA	01/31/95			
sheet	revision	AU	AU	AU	AU				
index	sheet	1	2	3	4				

PIN PLATING CODES:	
XXXX-1YY	30u"/0.76u MIN (SEE NOTE 9) OVER 50u"/1.27u MIN Ni
XXXX-2YY	15u"/0.38u MIN (SEE NOTE 9) OVER 50u"/1.27u MIN Ni
XXXX-3YY	50u"/1.27u MIN Au OVER 50u"/1.27u MIN Ni
XXXX-4YY	100u"/2.54u MIN Sn OVER 50u"/1.27u MIN Ni (SEE NOTE 10)
XXXX-4YYHLF	
XXXX-5YY	15u"/0.38u MIN (SEE NOTE 9) OVER 50u"/1.27u MIN Ni
XXXX-6YY	30u"/0.76u MIN (SEE NOTE 9) OVER 50u"/1.27u MIN Ni
XXXX-7YY	30u"/0.76u MIN Au OVER 50u"/1.27u MIN Ni
XXXX-8YY	15u"/0.38u MIN Au OVER 50u"/1.27u MIN Ni
XXXX-9YY	15u"/0.38u MIN GXT OVER 50u"/1.27u MIN Ni
XXXX-0YY	30u"/0.76u MIN GXT OVER 50u"/1.27u MIN Ni

**NOTES**

**1. PART NUMBER OPTIONS:**

PIN PLATING CODES (SEE ABOVE)

**HIGH TEMP. MATERIAL:**

FOR HIGH-TEMPERATURE APPLICATIONS, SPECIFY AN "H" AT THE END OF THE PART NUMBER, AND PCT WILL BE SUPPLIED.

**NUMBER OF POSITION:**

ANY NUMBER OF POSITIONS FROM 1 THRU 36.

**PACKAGING:**

PACKAGED IN POLY BAGS.

EIGHT DIGIT PART NUMBERS FOLLOWED BY A "T" ARE PACKAGED IN TUBES. SEE SPECIFIC PART NUMBERS FOR AVAILABILITY.

**LEAD FREE:**

ADD "HLF" SUFFIX AT THE END OF PART NUMBER FOR LEAD FREE OPTION, NOT AVAILABLE FOR -5YY,-5YYH,-6YY & -6YYH.

**2. BODY MATERIAL:**

MANUFACTURER'S OPTION OF NYLON OR PCT, GLASS FIBER REINFORCED, FLAME RETARDENT PER UL-94V-0. COLOR: BLACK.

PART NUMBERS WITH "H" SUFFIX WILL WITHSTAND EXPOSURE TO 260°C PEAK TEMPERATURE FOR 20 SECONDS IN WAVE SOLDER, INFRA-RED OR VAPOR PHASE SOLDER PROCESS.

PART NUMBERS WITHOUT "H" SUFFIX WILL WITHSTAND EXPOSURE TO 260°C PEAK TEMPERATURE FOR WAVE SOLDER PROCESS.

- 3. PIN MATERIAL: PHOS-BRONZE.
- 4. MEASURED WITH PART IN RESTRAINED CONDITION.
- 5. TWO SIDES OF PIN TIPS NOT PLATED. TYPICAL BOTH ENDS.
- 6. 2LBS/0.9KG MIN PIN RETENTION IN EITHER DIRECTION.
- 7. MILITARY BERGSTIK HEADER  
P/N XXXXX-XY-MIL  
NOT AVAILABLE.
- 8. THESE PRODUCTS MEETS EUROPEAN UNION DIRECTIVES AND OTHER COUNTRY REGULATION AS DESCRIBED IN GS-22-008.
- 9. PLATING OPTIONS:  
MAY BE EITHER GOLD OR GXT PLATED AT MANUFACTURER'S OPTION.
- 10. THIS PRODUCT HAS 100% TIN PLATING IN THE INTERFACE AND HAS NOT BEEN TESTED FOR WHISKER GROWTH IN ALL INTERCONNECT ENVIRONMENTS."

.100±.003 [2.54±.08]  
TYP. NON-ACCUMULATIVE

∅.040±.003 [1.02±.08]  
TYP.



RECOMMENDED HOLE PATTERN

mat'l. code SEE NOTES 2 & 3		surface ISO 1302	tolerance ISO 406 ISO 1101	projection 	product family BERGSTIK
ltr	ecm no	dr	date	tolerances unless otherwise specified	title
AU				angles linear .XX±.01/XX±.03 .XXX±.005/XX±.013 .000X±.0020/XXX±.0051	BERGSTIK® II HEADER .100/2.54cc SR R/A
				0°±2'	INCH/MM scale 2:1
		dr	T.BREWBAKER	01/31/95	dwg no 68015
		engr	T.HANNA	01/31/95	sheet 2 of 4 size A3
		chr	T.HANNA	01/31/95	type Product Customer Drawing
		appd	T.HANNA	01/31/95	
sheet index	revision sheet				

PRODUCT NUMBER	MATING LENGTH		TAIL LENGTH		BEND DIM		PACKAGING	LF OPTION
	DIM F	DIM F	DIM G	DIM G	DIM H	DIM H		
	ENGLISH	METRIC	ENGLISH	METRIC	ENGLISH	METRIC		
68015-YYY	0.230	5.84	0.090	2.29	0.060	1.52	POLY BAGS/TUBES	NOTE 1,8
68016-YYY	0.230	5.84	0.120	3.05	0.060	1.52	POLY BAGS/TUBES	
68023-YYY	0.135	3.43	0.305	7.75	0.135	3.43	POLY BAGS	
68417-YYY	0.230	5.84	0.390	9.91	0.060	1.52	POLY BAGS	
68423-YYY	0.318	8.08	0.120	3.05	0.060	1.52	POLY BAGS/TUBES	
68458-YYY	0.318	8.08	0.110	2.79	0.060	1.52	POLY BAGS	
68461-YYY	0.400	10.16	0.320	8.13	0.260	6.60	POLY BAGS	
68468-YYY	0.230	5.84	0.195	4.95	0.160	4.06	POLY BAGS	
68488-YYY	0.230	5.84	0.180	4.57	0.060	1.52	POLY BAGS	
68494-YYY	0.400	10.16	0.110	2.79	0.060	1.52	POLY BAGS	
68498-YYY	0.230	5.84	0.220	5.59	0.160	4.06	POLY BAGS	
68626-YYY	0.230	5.84	0.295	7.49	0.060	1.52	POLY BAGS	
68627-YYY	0.120	3.05	0.185	4.70	0.150	3.81	POLY BAGS	
68628-YYY	0.230	5.84	0.590	14.99	0.060	1.52	POLY BAGS	
68641-YYY	0.230	5.84	0.490	12.45	0.060	1.52	POLY BAGS	
68660-YYY	0.110	2.79	0.230	5.84	0.135	3.43	POLY BAGS	
68694-YYY	0.600	15.24	0.120	3.05	0.060	1.52	POLY BAGS	
68757-YYY	0.350	8.89	0.220	5.59	0.100	2.54	POLY BAGS	
68758-YYY	0.275	6.99	0.120	3.05	0.060	1.52	POLY BAGS	
68764-YYY	0.100	2.54	0.120	3.05	0.060	1.52	POLY BAGS	
68782-YYY	0.318	8.08	0.180	4.57	0.060	1.52	POLY BAGS	
68798-YYY	0.110	2.79	0.230	5.84	0.160	4.06	POLY BAGS	
69189-YYY	0.310	7.87	0.250	6.35	0.060	1.52	POLY BAGS	
71270-YYY	0.600	15.24	0.189	4.80	0.060	1.52	POLY BAGS	
72342-YYY	0.120	3.05	0.250	6.35	0.060	1.52	POLY BAGS	
78230-YYY	0.310	7.87	0.330	8.38	0.060	1.52	POLY BAGS	
78231-YYY	0.310	7.87	0.290	7.37	0.060	1.52	POLY BAGS	

mat'l. code SEE NOTES 2 & 3				surface ISO 1302 <input checked="" type="checkbox"/>		tolerance ISO 406 ISO 1101		projection 		product family BERGSTIK	
ltr	ecn no	dr	date	tolerances unless otherwise specified							
AU				angles	linear	.XX±.01/XX±0.3		INCH/MM		title BERGSTIK® II HEADER .100/2.54cc SR R/A	
				0°±2'		.XXX±.005/XX±0.13		scale 2:1		dwg no 68015	
				dr	T.BREWBAKER	01/31/95				sheet 3 of 4 size A3	
				enr	T.HANNA	01/31/95				type Product Customer Drawing	
				chr	T.HANNA	01/31/95					
				appd	T.HANNA	01/31/95					
sheet index	revision										



Copyright FCJ

PRODUCT NUMBER	MATING LENGTH		TAIL LENGTH		BEND DIM		PACKAGING	LF OPTION
	DIM F	DIM F	DIM G	DIM G	DIM H	DIM H		
	ENGLISH	METRIC	ENGLISH	METRIC	ENGLISH	METRIC		
78234-YYY	0.230	5.84	0.140	3.56	0.160	4.06	POLY BAGS	NOTE 1,8
78541-YYY	0.318	8.08	0.080	2.03	0.060	1.52	POLY BAGS	
78587-YYY			UNAVAILABLE					
78938-YYY	0.120	3.05	0.120	3.05	0.060	1.52	POLY BAGS	
78955-YYY	0.075	1.91	0.090	2.29	0.060	1.52	POLY BAGS	
78978-YYY	0.120	3.05	0.318	8.08	0.135	3.43	POLY BAGS	
79409-YYY			UNAVAILABLE					
84846-XXYH	0.140	3.56	0.290	7.37	0.153	3.89	POLY BAGS	
84917-XXYH	0.090	2.29	0.195	4.95	0.190	4.83	POLY BAGS	
84935-XXYH	0.450	11.43	0.320	8.13	0.260	6.60	POLY BAGS	
84936-XXYH	0.350	8.89	0.120	3.05	0.060	1.52	POLY BAGS	
87532-XXYH	0.230	5.84	0.890	22.61	0.060	1.52	POLY BAGS	
88813-YYY	0.230	5.84	0.085	2.16	0.060	1.52	POLY BAGS	
92050-YYY	0.162	4.11	0.120	3.05	0.060	1.52	POLY BAGS	
92632-YYY	0.100	2.54	0.318	8.08	0.060	1.52	POLY BAGS	
92909-YYY	0.400	10.16	0.220	5.59	0.060	1.52	POLY BAGS	
94099-YYY	0.157	3.99	0.090	2.29	0.060	1.52	POLY BAGS	
94529-XXYH	0.120	3.05	0.295	7.49	0.135	3.43	POLY BAGS	
94671-XXYH	0.090	2.29	0.085	2.16	0.180	4.57	POLY BAGS	
95653-XXYH	0.330	8.38	0.310	7.87	0.160	4.06	POLY BAGS	
95666-XXYH	0.230	5.84	0.145	3.68	0.060	1.52	POLY BAGS	NOTE 1,8
10089061-YYY	0.125	3.18	0.318	8.08	0.135	3.43	POLY BAGS	



Copyright FCJ

mat'l. code SEE NOTES 2 & 3				surface ISO 1302 <input checked="" type="checkbox"/>		tolerance ISO 406 ISO 1101		projection 		product family BERGSTIK	
ltr	ecrn no	dr	date	tolerances unless otherwise specified							
AU				angles	linear		INCH/MM		title BERGSTIK® II HEADER .100/2.54cc SR R/A		
				0°±2'	.XX±.01/XX±0.3		scale 2:1		dwg no 68015		
				dr	T.HANNA 01/31/95		sheet 4 of 4 size A3		type Product Customer Drawing		
				enr	T.HANNA 01/31/95		FCJ				
				chr	T.HANNA 01/31/95						
				appd	T.HANNA 01/31/95						
sheet index	revision										
	sheet										